

**Instructions  
for Installation,  
Operation and  
Maintenance of**

***STREAMLINE***  
***CENTRIFUGAL PUMPS***



DISTRIBUTED BY:

# INSTALLATION

## LOCATION OF UNIT

The pump should be placed as near the liquid source as practical so that a short direct suction pipe may be used. The pump should be accessible for inspection and repair work and headroom be provided for crane, hoist or tackle if the pump is heavy.

## PIPING

Both the suction and discharge lines should be independently supported near the pump so that no strain will be thrown on the casing.

### Suction Piping

The suction line should be as short and straight as possible and containing a minimum number of bends. Any bends necessary should have large radii. Generally the suction pipe is made one or two sizes larger than the pump suction branch. For pumps operating with suction lift no valves other than a foot-valve should be placed in the suction line. All these precautions ensure the maximum available suction head on the pump. Reducers must be eccentric if installed in a horizontal position (Fig. I). A straight taper reducer (Fig. II) should not be used in a horizontal suction line, because it may form an air pocket (IIA) in the top of the reducer and the pipe.

It is very important to have the suction line air-tight and to avoid undulations in which air may collect and destroy the vacuum. Where adverse suction conditions may cause the pump to lose its prime, the use of an external automatic priming device such as a vacuum pump is recommended.

Ensure that the system is free from foreign matter such as pipe scale, welding beads, dirt, etc. It is suggested to flush the whole system before going into operation. If possible use a temporary suction screen for removal of material in the pipe system.

For a given suction lift, suction capacity depends on the temperature of the liquid. For water 70°C (160°F) or above, care should be taken to ensure that enough pressure is available at the impeller entry to prevent vapourisation.

### Foot Valve

Should have a free area of at least one and a half times the area of the suction pipe.

An efficient strainer should be provided to prevent foreign matter from being drawn into the pump or choking the foot valve. When there is any refuse such as sticks, twigs, leaves, etc., in the water, a larger

outside screen, or a large basket strainer should be placed around the suction inlet to prevent choking the strainer. This screen should have sufficient openings to keep the flow through it below 0.6m (2 feet) per second.

### Discharge Piping

Generally the discharge piping is made one size larger than the pump discharge branch size. The discharge line should be short and direct with the least number of bends and fittings, thus minimising the head lost by friction. A non-return valve and discharge valve are usually placed in the discharge line. The non-return valve is to protect the pump from excessive back pressure and reverse rotation of the unit, and to prevent back flow into the pump in case of stoppage or failure of the driver. The discharge valve is used to regulate the flow. The non-return valve is placed between the discharge valve and the pump so that it may be inspected or repaired without emptying the discharge line.

### Foundation

The foundation should be substantial to reduce vibrations and rigid enough to avoid any twisting or misalignment.

### Alignment

The pump driver, if supplied, is correctly aligned on its baseplate at the factory. A certain amount of deformation of the baseplate is possible during transit and it is therefore essential to check alignment before going into operation. The pump shaft should be checked for angular and parallel alignment. A flexible coupling will not compensate for misalignment. Inaccurate alignment results in vibration and excessive wear on the bearings, sleeve or shaft and wear-rings.

The check for angular alignment (Fig. III) should be made by inserting a pair of inside calipers or taper gauge (IIIA) at four points, spaced at 90° intervals, between the coupling faces which must be within 0.07 mm (0.003"). A check for parallel alignment (Fig. III) is made by placing a straight edge (IIIB) across the coupling rim at the top, bottom and at both sides. The unit will be in parallel alignment when the straight edge rests evenly on the coupling rim at all positions.

### Grouting

A space of approximately 25mm (1") should be left between the baseplate and top of the foundation to be filled with grouting. After the grouting has dried the foundation bolts should be firmly tightened and alignment re-checked.

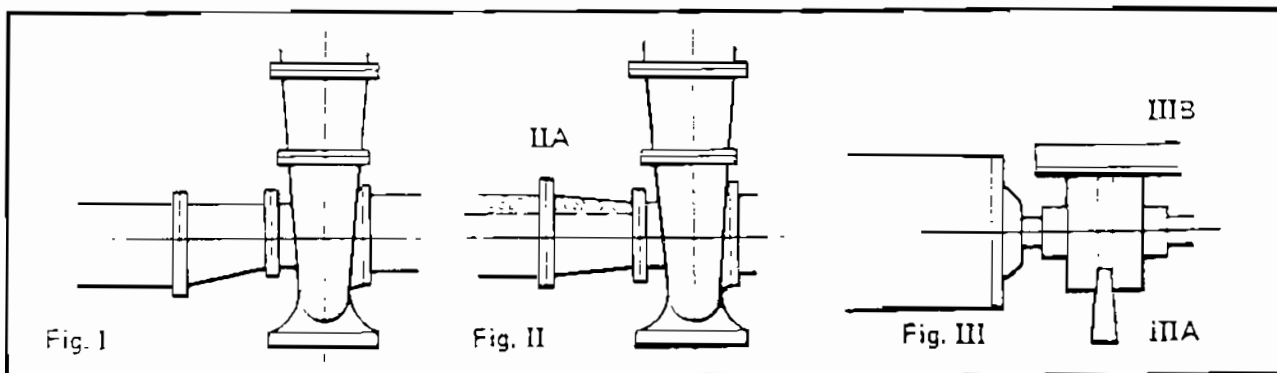

# OPERATION

## ELECTRIC MOTOR DRIVE

Install a starter with overload protection to prevent the motor being damaged by overload. The overloads should be set so that they trip if the current exceeds the nominal current of the motor (see motor nameplate) by 10%.

(N.B. Fire pumps may require exemption from this note)

## BEFORE STARTING

The pump is ready for starting when:

- Pump base-plate is grouted and bolted to the foundation.
- Pump and driver are correctly aligned.
- Bearing lubrication is provided.
- Stuffing-box has been packed or fitted with seal.
- Cooling water is supplied to bearing — if specified.
- Prime-mover has been checked for correct direction of rotation.
- All rotating parts are found free by turning by hand.
- Pump is primed. Never run a pump dry. The liquid in the pump serves as a lubricant for close running fits within the pump and the pump may be damaged if operated dry for an extended period. The pump may be primed by using an ejector, exhaustor or vacuum pump. If a foot valve is used in the suction line, the pump may be primed by venting and filling the casing with liquid.

## STARTING

Start the pump with discharge valve closed and bring it up to speed rapidly. When pressure is reached, open discharge valve slowly. Do not operate unit for prolonged periods with closed discharge valve, so as to avoid over-heating.

The pump should be shut down at once and the trouble corrected if the pump is running at its rated speed and found to have any of the following defects:

- No liquid delivered.
- Not enough liquid delivered.
- Not enough pressure.
- Loss of liquid after starting.
- Vibration.
- Motor runs hot.
- Pump bearing over-heating.

## RUNNING

While the pump is running, a periodic inspection should be made of:

### a) Stuffing-box

Keep stuffing-boxes (if soft packed, not fitted with mechanical seal) so that there is sufficient leakage to lubricate the packing.

### b) Bearing

Check the bearing for temperature which should not exceed 70°C (160°F).

Grease nipples are provided for bearing lubrication.

The grease lubrication interval is dependent upon a number of factors and may vary with each application. As a guide the period of lubrication should be approximately every 1,000 running hours.

When the pump is used infrequently add lubricant every 12 months and rotate shaft by hand a few revolutions each week.

### c) Alignment

Successful operation of the pumps depends on accurate alignment. It is recommended to re-check the alignment after preliminary run.

## OPERATING TROUBLES AND THEIR CAUSE

### Defects

Cause	Defects						
	No liquid delivered	Not enough liquid delivered	Not enough pressure	Loss of liquid after starting	Vibration	Motor runs hot	Pump bearings over-heat
1 Pump not primed	•						
2 Speed too low	•	•	•				
3 Speed too high						•	•
4 Air leak on suction	•	•		•	•		•
5 Air leak in mechanical seal		•		•			
6 Air or gas in liquid			•	•	•		•
7 Discharge head too high (above rating)	•	•	•			•	
8 Suction lift too high				•			
9 Not enough suction head for hot liquid		•					
10 Inlet pipe not submerged enough	•	•		•	•		•
11 Viscosity of liquid greater than rating		•	•			•	
12 Liquid heavier than rating						•	
13 Insufficient nett inlet head	•	•		•	•		•
14 Impeller plugged up	•	•			•		
15 Wrong direction of rotation	•	•	•				
16 Excessive wear ring clearance		•	•				
17 Damaged impeller		•	•		•		
18 Rotor binding						•	
19 Defects in motor						•	
20 Voltage and/or frequency lower than rating						•	
21 Incorrectly lubricated							•
22 Foundation not rigid					•		
23 Misalignment of pump and driver					•	•	•
24 Bearing worn					•		
25 Rotor out of balance					•		•
26 Shaft bent					•	•	•
27 Impeller too small			•				

# MAINTENANCE

## ROUTINE TEST

1) Hand test bearing housing for any sign of temperature rise. Temperature should not exceed 70°C (160°F).

A rise in temperature may indicate the early stages of bearing trouble.

2) Listen for any unusual noise developing.

### Look for

- a Loose stud bolts holding coupling guard.
- b Worn coupling.
- c Air trapped in pump.
- d Hydraulic noise, if the suction conditions have changed, causing minor cavitation.
- e Small solids entering pump.

3) Note the suction gauge reading and confirm that it is usual.

If it is higher than normal, find out why:

- a Has a valve in the supply system been partially closed?
- b Has the static suction lift increased?

4) Note the discharge gauge reading and confirm that it is as usual.

If lower than normal:

- a Inspect for serious leakage anywhere, owing to pipe fracture.
- b A valve in the delivery line may have been fully opened, which was previously partially closed.

## STUFFING-BOX

Installing the packing:

### A) Preparation:

- a) Remove all rings of old packing, and lantern ring (if fitted, Fig. 1-2): Use extractor (2A) to extract packing entirely, without damaging shaft or stuffing-box bore.
- b) Clean shaft and bore of box with clean oily cloth: also the lantern ring (if fitted).

b) When the correct number of rings have been inserted the last packing ring should never protrude past the stuffing-box face, so that gland may be properly started in the stuffing-box bore (1B).

c) Install gland (1C) and tighten finger tight only. When pump has been running for ten minutes at full pressure adjust nuts (1D) by sixth turn; continue to adjust at ten minute intervals. Small leakage must be allowed to ensure the packing is lubricated.

### B) Fitting:

Packing can now be installed in the stuffing-box. Follow this instruction to ensure trouble-free operation of stuffing-box:

**Caution:** Excessive gland pressure will cause damage by cutting off lubrication to the packing, and packing will burn and damage shaft.

If the packing is to be cut from a coil, or long length, obtain size, length and number of rings from Table 1 (if given).

- a) Insert the first ring and tap it to the bottom of the stuffing-box. Each following ring should be installed in the same manner and positioned in the stuffing-box (Fig. 1), so that "split" (1A) is advanced 90°. Install any lantern ring in its proper position to align with the sealing connection, allowing for movement of the ring deeper into the box as the packing is compressed.

Wrap the packing around a dummy shaft, equal to shaft diameter (Fig. 1-d) in the manner shown in Fig. 3. Over lapped split (4A) of the ring provide better sealing.

If packing is cut out of flat strip, the ends of packing (5A) will never seal and will develop leakage.

