

EBSRAY PUMPS

INSTALLATION, OPERATION & MAINTENANCE INSTRUCTIONS



L SERIES MODEL L80 LOBE PUMP

CONTENTS

SECTION 1 – GENERAL	3
1.1 INTRODUCTION	3
1.2 TRANSPORTATION, PACKING & STORAGE	3
1.3 RECEIVING INSPECTION	3
1.4 HANDLING	3
1.5 WARRANTY	3
SECTION 2 – INSTALLATION	4
2.1 LOCATION	4
2.2 FOUNDATIONS	4
2.3 PUMP PIPING CONNECTIONS	4
2.4 STRAINER PROTECTION	4
2.5 COUPLING ALIGNMENT	4
SECTION 3 – OPERATION	5
3.1 DESCRIPTION	5
3.2 LUBRICATION	5
3.3 BYPASS VALVE	5
3.4 PRE-STARTUP CHECKLIST	5
3.5 OPERATIONAL CHECKS	5
3.6 PERIODIC INSPECTION	5
SECTION 4 – MAINTENANCE	6
4.1 PREPARATION FOR DISASSEMBLY	6
4.2 DISASSEMBLY	6
4.3 INSPECTION	6
4.4 SPARE PARTS	6
4.5 REASSEMBLY - PRELIMINARY	6
4.6 REASSEMBLY	7
SECTION 5 – TROUBLESHOOTING	7
SECTION 6 – PARTS DESIGNATION	8

IMPORTANT NOTES

- This Publication is **TYPICAL ONLY** and only relates to the specifications of the minimum equipment required to ensure the optimum performance, maximum life and trouble-free operation of the Ebsray L Series Model L80 Lobe Pumps.
- Products with the mandatory European CE mark affixed indicate conformity to the essential health and safety requirements via their applicable EU Directives (e.g. ATEX 94/09/EC, Machinery 98/37/EC etc).
As certain specific products/equipment outlined in this Publication are CE marked (meaning the equipment has been assessed and supplied in conformity to those Directives), **STRICT ADHERENCE** with **ALL** the instructions and recommendations forms an essential part in maintaining the product/equipment's conformity.
Failure to comply with the instructions and recommendations contained in this Publication may void CE conformity.
- This Publication does **NOT** depict:
 - Ancillary required equipment related to the fabrication, installation and operation of the Pump e.g. miscellaneous flanges, fittings etc.
 - Required equipment unrelated to the Pumpset e.g. tank fill lines, vapour return lines, emergency shutdown systems etc.
 - The materials and method of fabrication of any required sub-systems.
- It is the responsibility of the designer, fabricator and the installer of each required sub-system to ensure that:
 - The Ebsray specifications within this Publication and any other relevant Ebsray documents are **STRICTLY** adhered to.
 - Any variation (including use of equipment deemed "Equivalent") or addition to the Ebsray Specifications, as related to the Pumpset and Pumping System in general, meet Ebsray's minimum requirements.
 - All design, fabrication and installation of the tank and sub-systems is **STRICTLY** in accordance with all relevant National, State and Local Directives, Standards, Codes and Regulations.
- Ebsray reserves the right to:
 - Withdraw or alter any or all of the Ebsray specifications within this Publication and any other relevant Ebsray documents without notification.
 - Determine the validity of any Warranty claims for Ebsray equipment based on the proper application of Ebsray supplied equipment by the way of adherence to the Ebsray specifications within this Publication and any other relevant Ebsray documents.

EBS-RAY PUMPS Pty. Limited
628 Pittwater Road
Brookvale NSW 2100 Australia
Phone: (+612 9905 0234)
Fax: (+612 9938 3825)
www.ebsraypumps.com.au

or Contact Ebsray Representative:

Terms used in this publication requiring special attention



DANGER

1. *Non-compliance with requirements under this heading could create circumstances which may lead to serious personal injury or death or substantial property damage.*



WARNING

2. *Non-compliance with requirements under this heading could create circumstances which may lead to personal injury and/or which may cause damage to the Pumpset and/or ancillary equipment.*



CAUTION

3. *Items under this heading draw attention to legal and/or statutory requirements which control the installation and use of this type of equipment. Non-compliance with these requirements may create a dangerous situation and/or result in damage to the Pumpset and ancillary equipment.*

NOTE:

4. *Items under this heading are to draw attention to assembly procedures, techniques and methods of operation, etc. which are important to ensure correct installation and operation of equipment and which, if not followed may result in damage, failure or poor performance of Pumpset and ancillary equipment.*

SECTION 1 – GENERAL

1.1 INTRODUCTION

This publication is intended to assist those involved with the installation, operation and maintenance of Ebsray L Series Model L80 Lobe Pumps.



DANGER

Before starting any work, this publication should be completely read/reviewed by all persons involved with the work. If any part of this publication is unclear, obtain clarification before proceeding with any work.



WARNING

These instructions are intended to assist correct pump installation, operation and maintenance requirements. They are additional to, and do not supersede or override any applicable statutory, legal or regulatory requirements.

The design, materials and workmanship incorporated in the manufacture of Ebsray pumps make them capable of reliable operation over a long working life. Correct installation and operation is essential. Service life is enhanced by periodic inspection and careful maintenance.



CAUTION

Installation and servicing of this equipment should be performed by qualified competent personnel in accordance with relevant Directives, Standards, Codes, Regulations and site restrictions, in conjunction with these instructions.

When the equipment supplied utilises components other than those manufactured by Ebsray e.g. electrical equipment, switches, fittings, valves, etc reference should be made to the original manufacturer's data before installation or servicing is commenced. Failure to observe these details may void the Warranty.



WARNING

The pump/pumpset must be operated within the original selected design parameters of pumped product, speed, flow, pressure, temperature, voltage and current. Should any change be contemplated, please confer with Ebsray in order to verify the suitability of such a change

1.2 TRANSPORTATION, PACKING & STORAGE

Standard domestic packing is suitable for shipment in covered transports. Pump ports must be sealed to exclude ingress of condensation, moisture or foreign material. When received on site the Pumpset must be stored in a dry covered area.

NOTE: *If Pump is not installed and commissioned immediately, special preservative techniques will be required. (Refer to Ebsray). e.g. If the Pump is installed, but not commissioned, low pressure nitrogen can be used to purge, seal and protect the Pump from the effects of condensation and atmospheric corrosion.*



WARNING

NEVER allow water or any corrosive product to enter the pump (e.g. for hydrostatic testing of pipework). Severe internal damage may result and will void the Warranty

1.3 RECEIVING INSPECTION

SHORTAGES and/or DAMAGE: On receipt of equipment, check all items against the dispatch documents and inspect for damage. Any damage or shortage incurred during transit should be noted on the packing note and on both your own and the carrier's copy of the consignment note. A claim should be made immediately on the transport company. Also advise Ebsray or their Appointed Representative. Should a shortage be evident on receipt, notify Ebsray immediately giving full details and packing note number.

1.4 HANDLING

Do not drop Pump! Care should be taken in moving/handling Pump/Pumpsets. A sling should be placed under or around a bare shaft pump to minimise stress on the internal components or pump flanges. Baseplate mounted units should be lifeted from under the baseplate below both the epump and driver. The Pump/Pumpset should be lifted in such a manner as to ensure compliance with the relevant lifting codes. **Severe internal Pump damage may result if correct handling and due care is not taken.**

1.5 WARRANTY

1. All Ebsray manufactured pumps and equipment are warranted as standard for one (1) year against faulty workmanship and/or materials. Refer to Ebsray PUMPS 'Standard Conditions of Sale and Warranty' publication for details.
2. Ancillary equipment supplied by Ebsray but manufactured by others will be in accordance with those manufacturer's written warranty conditions

SECTION 2 – INSTALLATION

CAUTION *Installation and removal of this equipment should be performed by suitably qualified competent personnel in accordance with relevant Directives, Standards, Codes, Regulations and site restrictions - in conjunction with these instructions.*

DANGER *Never loosen or remove fittings, flanges, etc. while under pressure, always isolate components or pipework and depressurise prior to work.*

2.1 LOCATION

The pumping unit should be placed as close as practicable to the source of supply keeping within the NPSHr of the pump. Ensure floor area and headroom allotted are sufficient for inspection and maintenance. Allow sufficient space and ventilation for motor cooling requirements. Be sure to allow for crane or hoist access if required.

2.2 FOUNDATIONS

Baseplate units should be accurately installed. When on a concrete foundation, ensure that it has been poured on a solid footing. Position foundation bolts to match baseplate foundation plan. Pumps/Pumpsets must be securely bolted down.

2.3 PUMP PIPING CONNECTIONS

NOTE: *Never draw piping into place by use of force at the port connections of the pump.*

All piping should be supported independently and line up accurately with the pump ports.

2.4 STRAINER PROTECTION

The pump suction should always be protected by an efficient suction strainer of adequate size to accommodate the liquid viscosity conditions without causing excessive suction resistance.

2.5 COUPLING ALIGNMENT

To maximise the life of the pump appropriate alignment of the coupled shafts is a fundamental requirement of any coupling installation.

NOTE: *Coupling types must be selected and installed in compliance with the relevant Directives, Standards, Codes, and Regulations dependant on application and location. (e.g. ATEX compliant – if applicable)*

Reference should be made to OEM coupling data for specific requirements however angular misalignment and parallel misalignment as shown in Figs 1 & 2 must be corrected.

If pump was supplied by Ebsray as part of a pumpset unit, pump and driver have been accurately aligned at factory. When incorporating these pumps into other equipment, manufacturers should ensure that coupling alignment is properly addressed.

To ensure that alignment has been maintained during transit and installation, alignment **MUST BE CHECKED** upon final installation and prior to startup.

Ensure 'distance between shaft ends' (DBSE) is correct for the type of coupling utilised.

ANGULAR MISALIGNMENT as shown in Fig.1 where shafts are at an angle to one another should be corrected before parallel misalignment.

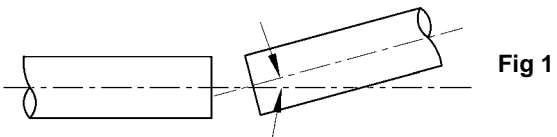

PARALLEL MISALIGNMENT as shown in Fig.2 where shafts are in line angularly and parallel to each other but are offset can now be corrected.

Adjustment by use of shims under the driver (or pump) will effectively correct error in the vertical plane.

Movement of one of the ends horizontally will correct error in the horizontal plane

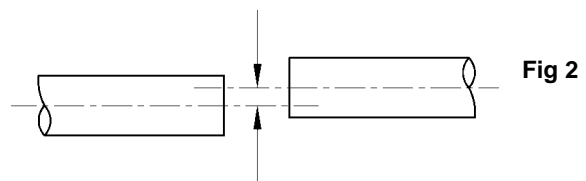

SECTION 3 – OPERATION

3.1 DESCRIPTION

The EBSRAY lobe principle is a positive displacement pump based upon the use of a driving inner rotor 'A', and an idling outer rotor 'B'. The spaces between the inner and outer rotor lobes, which are not involved in the meshing cycle, are virtually sealed by the close clearances between the inner and outer rotors, the liner and the end covers.

When rotation is started and the lobes come out of mesh, there is an increase in the space between the rotors on the inlet side. This creates a partial vacuum and the pressure differential thus created initiates movement of the liquid through the inlet port 'C', filling the space between the two rotors. When the lobes are fully unmeshed, the space between the rotors is filled with liquid. Transfer to the discharge side is effected as the liquid is carried past the upper seal zone 'E'. When the lobes begin to mesh on the discharge side the space between the two rotors is reduced, forcing liquid through the discharge port 'D'.

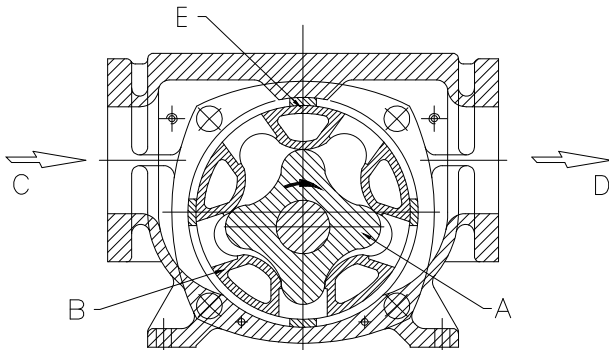

Fig 3

The field of applications for LOBE pumps is extensive. These pumps are used to handle many kinds of viscous liquids over a wide range of capacities, pressures and temperatures. Accordingly material, speed and power specifications vary and it is important to use such equipment strictly adhering to the manufacturer's recommendations.

3.2 LUBRICATION

Lubrication of the outer rotor, liner and rotor bearings is dependent on the pumpages' lubricating qualities, speed of rotation, differential pressure and material selection. External lubricators may be fitted and manufacturer's recommendations should be followed.

3.3 BYPASS VALVE

To protect the pump from overpressure due to inadvertent shutting of discharge system an inline bypass valve capable of circulating the entire pump output should be fitted. The valve should be installed in the pump discharge line and normally returns to the suction side of the pump or back to tank. Fluid temperature will rise if differential pressure is high and bypass conditions are maintained for extended periods. The bypass valve is normally set on commissioning. The bypass valve should be set on site in accordance with the predetermined pump or system differential pressure required. Refer separate instructions

3.4 PRE-STARTUP CHECKLIST



WARNING

Do not run Pump dry. Do not start Pump against closed discharge valve or with suction valve throttled. Failure to remove air/vapour could prevent pump from priming. Severe internal damage to the Pump will result, voiding Warranty.

- ▶ Lubricate as required.
- ▶ Check alignment of couplings.
- ▶ Ensure freedom of rotation of shaft.
- ▶ Check direction of rotation
- ▶ Ensure adequate steam supply for seal quench– if fitted
- ▶ Ensure liquid in pump is at correct temperature for pumping
- ▶ Open inlet and discharge valves



WARNING

To prevent damage to pump or system, disengage coupling before checking direction of rotation.

3.5 OPERATIONAL CHECKS

Inspect pump frequently during the first few hours of operation for such conditions as excessive heating of ball bearings, vibration or unusual noises etc.

3.6 PERIODIC INSPECTION

Periodic Inspection of the Pump, Pump System and Ancillary Equipment is required to maintain safety, conformity, operational functionality and reliability. Ebsray recommends a maximum interval of three months or 500 hours operation between routine periodic maintenance inspections (More frequent inspections may be necessary dependent upon usage, site conditions, operation etc).

If any abnormal condition is discovered, cease operation of pump immediately and take action to rectify the problem.

For safe operation, the following items should be included in the routine periodic inspection:

- a. Inspect the Pump for leaks, vibration, abnormal noises, signs of overheating, discolouration, etc.
- b. Inspect Coupling Assembly for signs of wear, overheating, discolouration, etc.
- c. Check Pump differential pressure

SECTION 4 – MAINTENANCE

CAUTION *Prior to any system disassembly or service, verify that all requirements of statutory Directives, Standards, Codes and Regulations, are met and that specific site requirements etc are satisfied*

Some minor maintenance tasks and inspections can be performed with the pump 'in line' so long as complete isolation, depressurising and purging procedures have been completed. However for major maintenance it is recommended that the pump be removed from the installation

4.1 PREPARATION FOR DISASSEMBLY

1. Obtain the appropriate Work Permit if required.
2. Isolate power supply to motor – if fitted.
3. Isolate pump from liquids in suction and discharge lines, depressurise and purge out any toxic, flammable, corrosive or air hardening liquids (if present).
4. Disconnect porting connections.
5. Remove pump from installation.
6. Mark relevant mating components for correct reassembly orientation

4.2 DISASSEMBLY

Refer to the Parts Designation drawing Fig 4 in Section 6

CAUTION Before proceeding, make sure body is firmly attached to baseplate or bench etc. to avoid overbalancing when rotor is withdrawn.

1. Remove suction/pressure circulation harness assemblies.
2. Remove pump coupling half and remove any burrs etc from shaft.
3. a) Hydraulic Packing Fitted Pumps:
Remove Gland, Packing and Lantern Ring (if fitted).
- b) Cartridge Seal Fitted Pumps:
Remove seal according to seal manufacturer's instructions
4. Remove inspection end bearing cap and cover setscrews.
5. Inspection end cover can now be removed, insert suitable setscrews (3/4" BSW.) into threaded jacking holes and tighten evenly to remove cover.
6. The rotor/shaft assembly can now be driven through the pump from the drive end taking care to adequately support the inspection end.
7. Remove drive end cover setscrews and drive end cover, as in 5. above.
8. Outer rotor and liner can now be removed
9. Press out rotor bearings if replacement is required.
10. Remove Packing and Lantern Ring.

4.3 INSPECTION

NOTE: *Optimum performance is achieved by maintaining the pump within the following guidelines.*

NOTE: *Adequate performance may still be achieved dependent on application parameters.*

Inspect components for damage or excessive wear, replace or repair as required. Particular attention should be given to areas where wear is likely to occur. These areas are: the driving and driven surfaces of the two rotors, the end covers, wear between outer rotor and liner, rotor bearings and mechanical seal components. If pump performance has been satisfactory, existing components although worn, may still have adequate service life.

Major refurbishing of the pump should be done in line with reconditioning to an 'as new' status as replacing or repairing one component will have an effect on other components and the working clearances of the pump.

Standard L80 Running Clearances Refer Section 6 – Fig 4	
Diametral – Shaft to Bearings (W)	0.20mm – 0.25mm
Diametral – Outer Rotor to Liner (X)	0.41mm – 0.50mm
Axial – Rotors to Covers (total) (Y)	0.30mm – 0.36mm

4.4 SPARE PARTS

1. When ordering spare parts, to ensure a minimum of delay and correct replacement to original specification, ALWAYS quote the pump Serial Number located on the nameplate of the pump.
2. Advise the name, Cat # and quantity required. Refer Section 6 – Parts Designation.
3. Advise complete delivery instructions, transportation, etc.

NOTE: *Substitute or so-called 'equivalent' item/spare parts are not recommended for use.*

Compliance, safe operation and pump performance may be severely compromised if incorrect or substitute spare parts – including Fasteners, O-Rings, etc – are used.

Only use genuine Ebsray spare parts.

4.5 REASSEMBLY - PRELIMINARY

1. Ensure all parts are clean and deburred before assembly.
2. If replacing rotor bearings: Press-fit ensuring lubrication groove in bearing is adjacent to greaser hole in cover. Fit bearings flush with inner cover faces. Care should be taken to ensure correct alignment. Drill through greaser hole, drill through and tap bearing lock screw hole (1/2" BSW). Using a suitable sealant on bearing lock screw, lock bearing in position. Machine or ream both bearings to achieve correct clearance on shaft, ensuring squareness with inner cover face.
3. Carry out preliminary sizing checks:(refer table of clearances)
4. a) Axial length of inner and outer rotor should be matched to within +/- 0,02mm.

- b) Outer rotor to liner diametral clearance.
 - c) Rotor bearings to shaft clearance.
5. Ensure all suction/pressure circulation harness assemblies are clear of any obstructions.
 6. EBSRAY recommend replacement of all gaskets, seals and "O"rings at every overhaul, to ensure positive sealing.



WARNING

At all times when handling and installing mechanical seals, care must be taken to ensure lapped faces and seats are not damaged. Particular attention must be given to carbon seats to prevent marking or chipping.

7. Lubricate all O-Rings and lapped faces of mechanical seals with a good quality, compatible, detergent-free light oil before assembly.
8. Ensure correct orientation of components relative to pump rotation/handling .

Pump Fastener Torque settings:	L80	
Casing Material	CI	CS
Cover to Body	650Nm	650Nm
Brg Cap to Body	52Nm	52Nm
Port Flanges	Dependent on Gasket	
(CI=Cast Iron, CS=Cast Steel)		

4.6 REASSEMBLY

(Refer Section 6 – Parts Designation)

1. Fit liner to body.
2. Lubricate and insert outer rotor in liner, check for freedom of rotation.
3. Fit locating pins and 'O' ring to drive end cover and fit assembly to body ensuring correct orientation. Locate accurately using locating pins. Tighten nuts firmly.
4. Lubricate rotor/shaft assembly and Insert through outer rotor with drive end through drive end cover.
5. Fit locating pins and 'O' ring and install the inspection end cover, ensuring correct alignment using the dowel pins. Tighten the cover nuts firmly.
6. Check rotor on shaft assembly for freedom of rotation. Axial clearance can be checked at this stage using a dial indicator.
7. a) Hydraulic Packing Fitted Pumps:
Fit Lantern Ring, Packing and Gland in accordance with Fig 4 – Section 6.
b) Cartridge Seal Fitted Pumps:
Install seal according to seal manufacturer's instructions
8. Replace suction / pressure circulation harness assemblies.
9. Replace inspection end bearing cap

SECTION 5 – TROUBLESHOOTING

5.1 PUMP FAILS TO PRIME OR DELIVER LIQUID

1. No liquid in tank.
2. Incorrect direction of rotation.
3. Speed too low - check speed, line voltage and phases.
4. System discharge head too high - check system head, friction losses and bypass valve setting.
5. Excessive suction restrictions - check NPSH available (inadequately sized suction piping may cause high friction losses, vapour pressure of liquid may be too high). Check with vacuum or compound gauge.
6. Air leaks and/or air pockets in suction line - check suction piping.
7. Suction filter/strainer blocked or leaking air.
8. Pump cannot clear vapour due to excessive discharge pressure e.g. static head.

5.2 LOW OUTPUT

1. Discharge head too high.
2. Entrained air or gases in liquid pumped.
3. Strainer offering excess resistance to flow.
4. Suction and/or discharge pipes of insufficient diameter, causing excessive friction loss.
5. Insufficient NPSH available.
6. Excess axial clearance setting of rotor to cover.

7. Excess clearances due to wear.

5.3 EXCESSIVE POWER CONSUMPTION

1. Differential pressure higher than rating.
2. Liquid properties not as specified - check viscosity.
3. Rotating parts bind - check for proper clearances or foreign matter in pump.
4. Bearings worn - inspect and replace as required.
5. Obstructions in pipe lines, clogged strainers, partially open valves.
6. Pump speed too high.
7. Voltage too low.

5.4 PUMP IS NOISY

1. Cavitation is taking place - increase NPSH by:
 - (a) Removing suction line restrictions created by:
 - (i) Inadequate pipe sizes / excessive line lengths.
 - (ii) Incorrect selection of valves, fittings etc.
 - (iii) Strainer not permitting free flow of liquid to pump.
 - (b) Increasing static head in suction vessel.
 - (c) Reduce product viscosity.
2. Rotating parts bind - check for proper clearances.
3. Pump and driver misaligned - check coupling and realign as required.

SECTION 6 – PARTS DESIGNATION

MODEL: L80 Lobe Pump.

Cat#	Description	Qty	Cat#	Description	Qty
1	Body	1	35	Outer Rotor	1
3	Cover – Inspection End	1	40	Shaft	1
4	Rotor Bearing – Inspection End	1	44	Bearing Cap – I.E.	1
6	Locating Pin – Cover	4	45	Setscrew – Bearing Cap	8
10	Cover – Drive End	1	47	O-Ring – Bearing Cap	1
11	Rotor Bearing – Drive End	1	60	Inner Rotor	1
12	O-Ring – Cover	2	67	Key – Rotor	1
14	Setscrew – Cover	8	94	Key – Coupling	1
17	Gland Plate	1	100	Lantern Ring	1
19	Stud and Nut – Gland Plate	2	111	Cartridge Seal Assembly	1
21	Packing	To Suit	132	Locating Pin – Liner	2

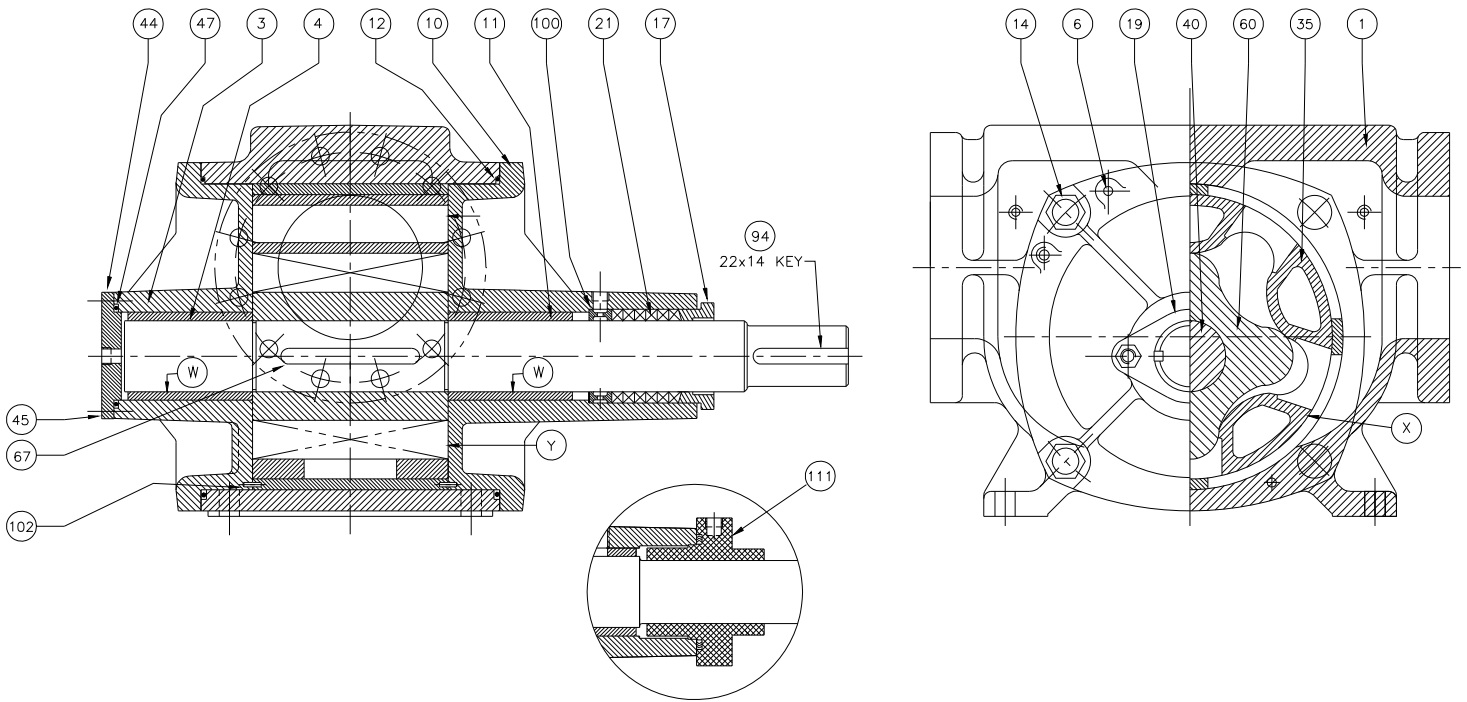

Fig 4